

MICRA

- Termosigillatrici sottovuoto da banco in atmosfera protetta
- Table top vacuum thermosealing machines with protective atmosphere
- Operculeuses sous vide et sous atmosphère protectrice à poser sur table
- Tisch-Vakuum-Thermoschweißgeräte mit Schutzgasausführung



VALKO®

vacuum packaging technology

made in Italy

MICRA

Mod.

MICRA 6

MICRA 8



Le termosigillatrici sottovuoto da banco in atmosfera protetta serie MICRA, costruite in acciaio inox e alluminio, rispondono alle molteplici esigenze di confezionamento della moderna distribuzione alimentare. La facilità e la rapidità della sostituzione degli stampi rendono possibile il confezionamento sottovuoto di svariati tipi di vaschetta.

CARATTERISTICHE

- Costruite in acciaio inox e alluminio
- Vasca in acciaio inox
- Campana in alluminio stampato
- Caricamento e passaggio film bobina protetto igienicamente
- N. 2 riduttori di volume in dotazione
- Partenza automatica ciclo

SPECIFICATIONS

- Built in stainless steel and in aluminium
- Lower chamber in stainless steel
- Upper chamber pressed in aluminium
- Loading and passage of the film spool hygienically protected
- No. 2 volume reducers
- Automatic start of the cycle

CARACTERISTIQUES

- Construites en acier inox et aluminium
- Cuve en inox
- Cloche en aluminium emboutie
- Chargement et passage bobine du film protégés hygiéniquement
- 2 réducteurs de volume en polyéthylène
- Départ automatique du cycle

PRODUKTDDETAILS

- Aus rostfreiem Stahl und Aluminium gebaut
- Untere Kammer aus rostfreiem Stahl
- Obere Kammer tiefgezogen aus Aluminium
- Ladung und Durchgang der Folie hygienisch geschützt
- 2 Polythen-Platten
- Automatischer Start des Zyklus

The vacuum thermosealing machines with protective atmosphere, MICRA series, built in stainless steel and aluminium, meet the several packaging requirements of the modern food distribution. The easiness and the rapidity in swapping the dies allow to package under vacuum several types of trays.

Les operculeuses sous vide et sous atmosphère modifiée série MICRA, construites en acier inox et aluminium, répondent aux nombreuses exigences d'emballage de la moderne distribution alimentaire. La facilité et la rapidité de remplacement des moules permettent l'emballage sous vide de différents types de barquettes.

Die Serie MICRA besteht aus Vakuum-Thermoschweißgeräten mit Schutzgasausführung, hergestellt aus rostfreiem Stahl und Aluminium. Diese Geräte entsprechen den unterschiedlichen Verpackungsansprüchen im Bereich des modernen Lebensmittelhandels. Dank des leichten und schnellen Austauschs der Siegelformen ist es möglich, eine zahlreiche Art von verschiedenen Schalen zu verpacken.

Optionals



- Stampo singola impronta per vaschette 140x195 mm
- Single die for trays 140x195 mm
- Outillage à empreinte unique pour barquette 140x195 mm
- Werkzeug einfache Aufnahme für Schalen 140x195 mm



- Stampo doppia impronta per vaschette 95x140 mm x 2
- Double die for trays 95x140 mm x 2
- Outillage à double empreinte pour barquette 95x140 mm x2
- Werkzeug doppelte Aufnahme für Schalen 95x140 mm x2



- Stampo singola impronta per piatto 180x180 mm
- Single die for standard tray 180x180 mm
- Outillage à empreinte unique pour barquette 180x180 mm
- Werkzeug einfache Aufnahme für Teller 180x180 mm



- Stampo singola impronta per vaschette GN 1/4 (160x260 mm)
- Die single impression for trays GN 1/4 (160x260 mm)
- Outillage à empreinte unique pour barquettes GN 1/4 (160x260 mm)
- Werkzeug einfache Aufnahme für Schalen GN 1/4 (160x260 mm)



- Stampo doppia impronta per vaschette GN 1/8 x 2 (160x130 mm x 2)
- Die double impression for trays GN 1/8 x 2 (160x130 mm x 2)
- Outillage à double empreinte pour barquettes GN 1/8 x 2 (160x130 mm x 2)
- Werkzeug doppelte Aufnahme für Schalen GN 1/8 x 2 (160x130 mm x 2)

- A richiesta si possono avere impronte di varie forme e dimensioni
- On request it is possible to get dies of different forms and sizes
- Sur demande il est possible d'avoir des empreintes de formes et dimensions diverses
- Auf Anfrage sind Werkzeuge von verschiedenen Formen und Größen erhältlich

- A richiesta è possibile avere la fustellatura di stampi speciali
- Customized profile cut for dies available on request
- Sur demande il est possible d'avoir des coupes aux contours d'outillages spécifiques
- Auf Anfrage wird die Folien-Schneidevorrichtung für kundenspezifische Werkzeuge angefertigt

MICRA

Optionals



- Supporto a mobile con ruote
- Stainless steel cabinet on wheels
- Piètement mobile
- Fahrbares Untergestell



- Compressore d'aria silenziato con serbatoio d'accumulo integrato nel supporto a mobile (modello da 5 litri)
- Silent compressed air generator with air tank housed in the cabinet (5 lt. model)
- Compresseur silencieux avec réservoir intégré dans le piètement mobile (modèle à 5 lt.)
- Schallgedämpfter Luftkompressor mit Luftspeicher im Untergestell integriert (5 Lt. Modell)



- Compressore d'aria silenziato con serbatoio d'accumulo (modello da 9 litri)
- Silent compressed air generator with air tank (9 lt. model)
- Compresseur silencieux avec réservoir (modèle à 9 lt.)
- Schallgedämpfter Luftkompressor mit Luftspeicher (9 Lt. Modell)



- Valvola di blocco per miscele ad alto contenuto di ossigeno ($O_2 > 21\%$)
- Safety vane for high oxygen ($O_2 > 21\%$) gas mixtures
- Electrovanne de sécurité à oxygène ($O_2 > 21\%$)
- Sicherheitsabsperrentil für Gasmischungen mit hohem Oxygeengehalt ($O_2 > 21\%$)







- Piastra saldante universale
- Universal sealing plate
- Plaque de chauffe universelle
- Universaler Schweißplatte



- Supporto a mobile
- Stainless steel cabinet
- Piètement mobile
- Untergestell

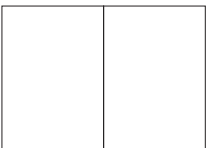

CONFIGURAZIONE STAMPI - MOULDS CONFIGURATION - CONFIGURATION DES MOULES -KONFIGURATION DER NUETZEN

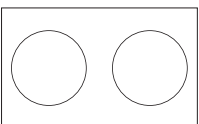
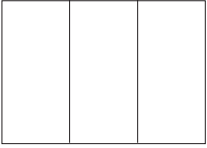
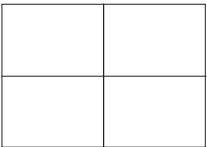
Impronte Impressions Empreintes Nutzen	Senza fustellatura Without profile cut Sans coupe autour Ohne Konturschneidung	Con fustellatura With profile cut Avec coupe autour Mit Konturschneidung
1	 270x190 mm	 260x160 mm
2	 130x190 mm	 120x160 mm
		 ø 100 mm
3	 80x190 mm	
4	 85x130 mm	

IMPORTANTE

- L'altezza massima possibile delle vaschette è di 85 mm
- Tutte le grandezze sono indicate in mm (millimetri) e sono intese come dimensioni massime possibili
- Ogni tipo di stampo può essere confermato solo dopo la visione di una campionatura di vaschette
- Ulteriori tipi di stampi sono possibili su richiesta

IMPORTANT

- The maximal height of the trays can be 85 mm
- All sizes are indicated in mm (millimetres) and are intended as maximum sizes possible
- Each type of mould can be confirmed only after having received some samples of trays
- Additional types of moulds are available on request

ATTENTION

- La hauteur maximale des barquettes peut être de 85 mm
- Toutes les dimensions sont indiqués en mm (millimètres) et ce sont les tailles maximales possibles
- Chaque type de moule peut être confirmé seulement après avoir reçu les échantillons
- D'autres types de moules sont disponibles sur demande

ZU BEACHTEN

- Maximale Höhe der Schalen ist 85 mm
- Alle Größen sind in mm (Millimeter) angegeben und sind die maximalen möglichen Größen
- Jede Art von Nutzen kann erst nach Betrachten des Ausfallmusters der Schalen bestätigt werden
- Andere Nutzen sind auf Anfrage erhältlich

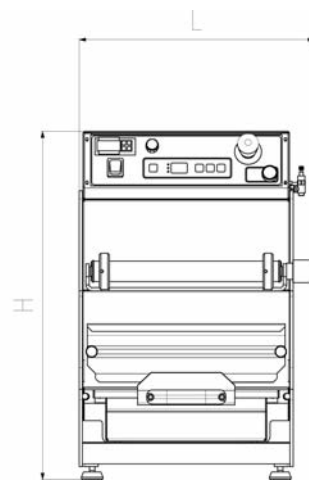
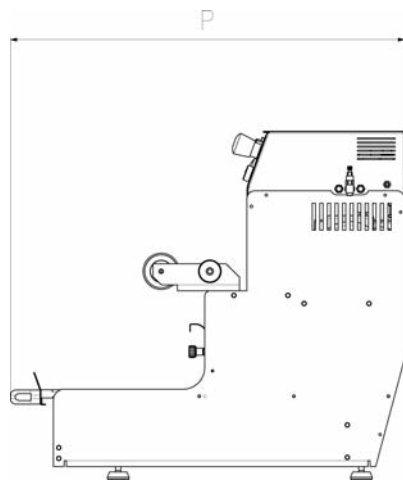

TECHNICAL INFO

Modello Model Modèle Modell	Larghezza Width Largeur Breite	Profondità Depth Profondeur Tiefe	Altezza Height Hauteur Höhe	Impronta max. stampo Max. impression of the die Empreinte max. sur l'outillage Max. Abdruck Siegelform	Altezza max. vaschetta Max. height of the cup Hauteur max. de la barquette Max. Höhe der Schale	Bobina / Roll Bobine / Rolle		Pompa vuoto Vacuum pump Pompe à vide Vakuumpumpe	Tensione Voltage Tension Spannung	Potenza Power Puissance Leistung	Peso Weight Poids Gewicht
						Larghezza Width Largeur Breite	Ø max. Max. Ø Ø max. Max. Ø				
MICRA 6	435 mm	730 mm	650 mm	270 mm x 180 mm	85 mm	290 mm	210 mm	6 m ³ /h	230V~	1200 W	kg 62
MICRA 8	435 mm	730 mm	650 mm	270 mm x 180 mm	85 mm	290 mm	210 mm	8 m ³ /h	230V~	1100 W	kg 62

VALKO®

VALKO srl
Via Berlino, 1
24040 Bottanuco
(Bergamo) Italy

▪ **Phone**
+39.035.4992010
Fax
+39.035.4992015

▪ www.valko.com
info@valko.com

Made in Italy



Le fotografie rappresentate contengono optional.
Pictures with accessories.
Les photos représentées sont avec des options.
Photos mit Zubehören.

La ditta VALKO si riserva il diritto di apportare qualsiasi modifica per il miglioramento delle sue apparecchiature.
VALKO reserves the right to change its equipment in order to improve it.
Document non contractuel. La VALKO pratique une politique d'amélioration permanente et se réserve le droit de
modifier ses appareils sans notification préalable.
Änderungen für Verbesserungen vorbehalten.